

2010

NATIONAL FORGING & HORSESHOEING COMPETITION RULES

JUDGES

Mark Milster, CJF
Troy Price, CJF
Jim Blurton, AWCF

JUDGING RULES

Judging is based upon rules set forth here, rules and information provided at the on-site competitors' meeting, drawings presented by the AFA Rules Committee, and by information forwarded in Chapter Nine of the AFA's Farrier Certification Program booklet. Competitors will be mailed a copy of the AFA booklet and a blank judging sheet after their entry is processed.

Forging and/or shoeing that fail to accord with these rules and specifications will be disqualified immediately and will not be scored or judged. During judging, competitors are not allowed to talk to judges. Doing so will be grounds for disqualification. Spectators may watch the judging process, but may not interfere with or question the judges.

When possible, horses and/or shoes will be available for inspection upon completion of judging. Judge's score sheets will not be available to competitors or spectators before the announcement of class winners.

RULES & INFORMATION

ENTRY: Forging competitions are open to everyone. There will be a flat fee of \$300 for AFA members and \$450 for non-AFA members to enter all classes. The Draft Class is a separate entry. **All entries must be post-marked by January 1, 2010.**

ON-SITE VETERINARIAN: A veterinarian will be present during all live shoeing activities. If a medical condition occurs during shoeing, time will be stopped and an examination completed. If the competitor causes such a condition, s/he will be disqualified. If the competitor does not cause such a condition, s/he may continue without penalty.

HORSE HANDLERS: Each competitor is responsible for supplying his or her own horse handler in live shoeing classes. The handler will not aid, assist, advise, or in any way be involved with the competitor during shoeing. No restraining device, such as a twitch or war bridle, is permitted. The use of lip, mouth, nose or bar chain is allowed, provided no abuse to the animal is rendered by its use.

NORTH AMERICAN CHALLENGE CUP

Sponsored by Vector Horseshoe Nails

VECTOR NACC / QUALIFIER CLASS

The Vector NACC Qualifier Class, open to all competitors, requires competitors to forge two shoes: a roadster and a front shoe. The shoes are judged and placed from one to twenty, with the top twenty finishers qualifying to compete in the Vector NACC Live Shoeing class.

FRONT SHOE (NOT PICTURED)

- 12" x 5/16" x 3/4"
- Fullered, toe clipped
- Punched for six nails
(Vector 5CH or 5SB)

ROADSTER

- 11" x 1/2" x 1"
- Toe clipped
- 5" wide (width of shoe to be taken at the widest part of the hoof surface). Tolerance +/- 2 millimeters
- Punched for six nails
(Vector 6E Slim)

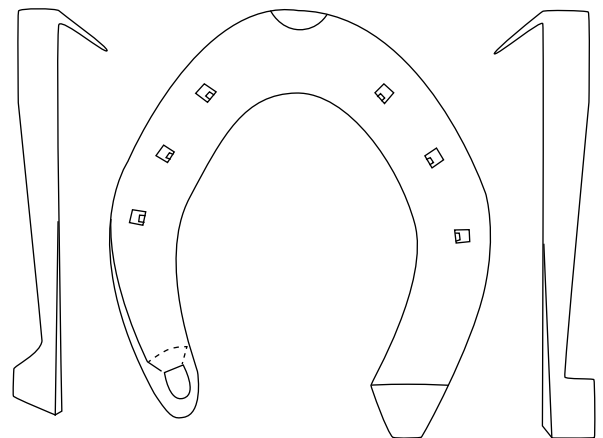

Time Limit: 45 minutes

STEWARDS: A steward will be assigned to each competitor. The steward shall ensure compliance with the competition rules by the competitor and recommend disqualification to the Chief Steward for any breach of rules. In live shoeing classes, the steward will bring the horse to the competitor's horse handler and return the horse to the holding area after competition.

DISQUALIFICATION: Prior to judging, the Chief Steward has the final authority to disqualify competitors for non-compliance with stated rules and/or for other inappropriate actions, including but not limited to using abusive or profane language, evidencing general conduct unbecoming of a professional farrier, laming a horse during live shoeing, and/or abusing a horse during live shoeing.

BAR STOCK: All bar stock will bear the mark of the AFA and will be furnished to competitors just before the Chief Steward calls for the competition to begin. Bar stock may not be marked or cut by the competitor before starting.

PROPANE: In the interest of safety, propane

cylinders are rented at the competition site, and no outside cylinders are allowed. Competitors will list and pay for the number of cylinders they require on their entry forms. Upon arrival, competitors will be issued coupons for the number of propane cylinders ordered.

SAFETY GLASSES: All competitors are required to wear safety glasses while competing. Failure to do so will result in disqualification.

TOOLS AND DEVICES: Hand tools and top anvil tools are allowed. No mechanical benders or devices are permitted. A top anvil toe bender that is non-mechanical, non-hydraulic, or non-electric (or any other device powered by the competitor) is considered a top anvil tool and is permitted. Grinders, stall jacks, portable anvils, or devices other than a stationary anvil are not allowed. A shoeing block or foot stand shall be used only to rest horse hooves.

FOREIGN MATERIALS: All shoes and feet must be completely free of foreign material. Waxing, oiling or otherwise treating shoes or hooves will result in disqualification.

AFA TEAM MEMBERSHIP: To be eligible for the American Farriers' Team, a competitor must be an AFA member in good standing, an AFA Certified Journeyman Farrier, and a citizen of the United States or have permanent resident status residing in the USA.

SITE INFORMATION: This year's competition will be held in the Oregon Convention Center. The working surface will be concrete; mats will be provided.

AWARDS: In addition to the awards mentioned with the specific classes, other awards include an Overall High Point Award (sponsored by Michael Chisham, CF, and Western States Farriers Association) and a Reserve National High Point Award (sponsored by the Farrier Industry Association). Additional awards and sponsors will be announced at the competition.

VECTOR NACC / LIVE SHOEING CLASS

The top twenty competitors from the Vector NACC Qualifier Class will compete in the Vector NACC Live Shoeing Class in reverse order, with the competitor in 20th place competing first and the competitor in first place competing last. Forging the same shoes as made in the Vector NACC Qualifier Class, competitors will shoe one front foot and make a specimen shoe for the opposite hind foot.

The front foot will be shod with a hand-forged shoe made from 14" x 5/16" x 3/4" bar stock. The toe-clipped shoe will be fullered and punched with six nail holes for Vector #5 city head or Vector #5 slim blade nails, which will be provided by the stewards. Competitors must use the required number of nails per shoe.

The roadster specimen hind shoe to be forged for the opposite hind foot will be made from 11" x 1/2" x 1" bar stock. The shoe will be punched for six nails (Vector 6E Slim) and toe-clipped. The specimen shall be 5" wide (tolerance +/- 2 millimeters), with the width measured at the widest part of the hoof surface.

If the horse has a shoe on, the competitor may not remove it until the start of the class. The competitor may not pick up the foot to clean or otherwise inspect it before the start of the competition. The competitor

will notify the steward when the foot is ready to be judged.

A time limit of 15 minutes is set for hoof preparation, and, to facilitate the judging process, competitors will begin at specific intervals. The first judge will score the dressed foot. The next judge will score shoe quality and fit. Stewards will notify the judge when this portion is ready to be judged. Competitors should allow enough time to nail and finish. After time expires, the third judge will score nailing and finish.

A finished job is defined as a foot with nails clinched, which by definition means the nails are at least bent down against the hoof wall. A competitor will be disqualified if the time limit is exceeded. The competitor must complete the horse, even if time has expired.

A scoreboard will show names and scores of the top ten competitors as the class progresses. However, scoring for the specimen shoes will be kept confidential until the AFA Awards Banquet, at which time score sheets will be available.

Time Limit: 60 minutes

DELTA SPECIALTY FORGING CLASS

Sponsored by Delta Mustad Hoofcare Center

The AFA Rules Committee will select three shoes from a list of six. Competitors will not know which shoes they will make until the on-site competitors' meeting.

TIME LIMIT: 90 minutes

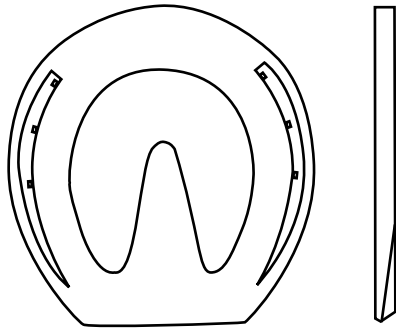

ALUMINUM HEART BAR FRONT

- 14" x 3/8" x 1"
- fullered
- punched for 6 nails (Delta 5 Combo)

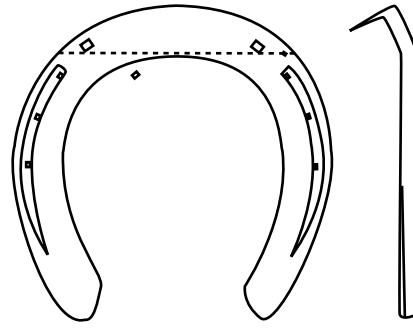

DUTCH ROCKER TOE FRONT

- 13 1/2" x 3/8" x 1"
- masselotte clip
- toe nails punched
- branches fullered
- rocker toe
- punched for 8 nails (Delta 6E)

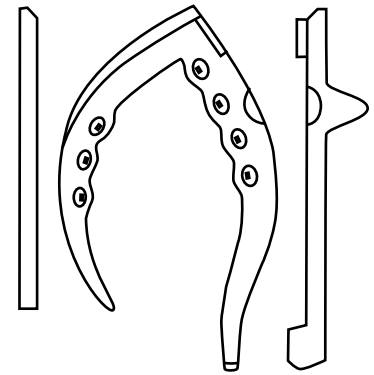

SADDLEBRED CROSSFIRE HIND

- 11" x 1/2" x 3/4"
- oval punched
- brazed caulk from 1/4" round
- lateral heel caulk & side clip
- clip height for pad
- punched for 7 nails (Delta 7 City)

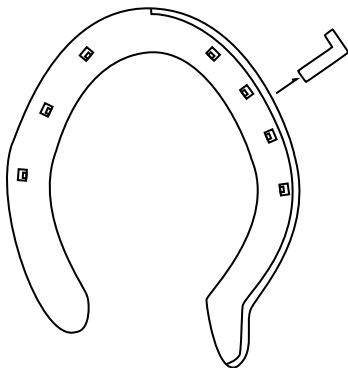

HIND SHOE WITH BRAZED ON OUTER RIM

- 12" x 1/4" x 3/4"
- Rim to Run from Center of Toe to Trailer and follow shape of Trailer
- Rim Stock 18" x 1/4 x 1/8
- Punched
- 7 Nails, Delta 4 1/2 City

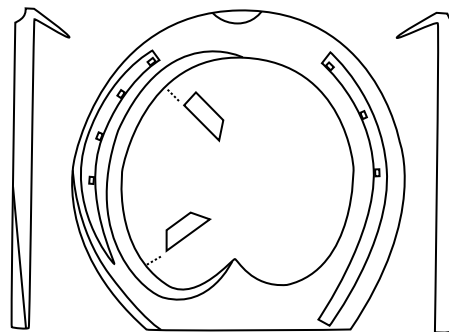

MEDIAL SUPPORT STRAIGHT BAR SHOE

- 15 1/2" x 5/16" x 1"
- Toe Clip
- Fullered
- 7 Nails, Delta 3E

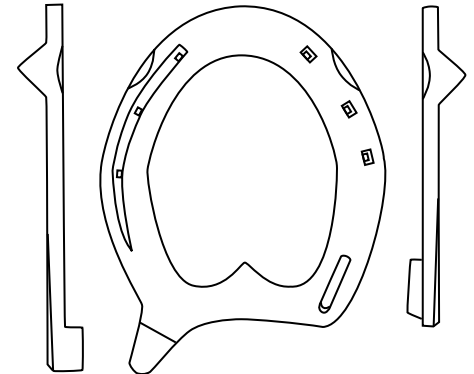

HIND BAR SHOE

- 14" x 5/16" x 3/4"
- Outside Branch, Fullered & Heel Calk
- Inside Branch, Brazed Jar Calk in line with Branch (from 16" of 1/4" round)
- Quarter Clips
- 6 nails, Delta 5 Slim

TWO-PERSON DRAFT CLASS

Sponsored by Anvil Brand

Farriers who have been members of a national team (any nation) past or present may not work together in this class. One farrier will make a pair of front shoes; the other farrier will make a pair of hind shoes. The shoes to be made by the first farrier are not specified. Points are awarded equally to each farrier.

One competitor will make one pair of front shoes from 18" x 1/2" x 1 1/4", hammer-drawn toe clip, scotch heels, fullered, and punched for eight 10E nails.

The other competitor will make a pair of hind shoes from 17" x 1/2" x 1 1/4", hammer-drawn toe clip, scotch heels, fullered, punched for seven 10E nails.

Steel for the second set of shoes can enter the fire when the first pair comes out for the last time, but the second set cannot be taken from the fire until the first set is on the ground. Filing or rasping is prohibited, and no flatters are allowed.

TIME LIMIT: 70 minutes

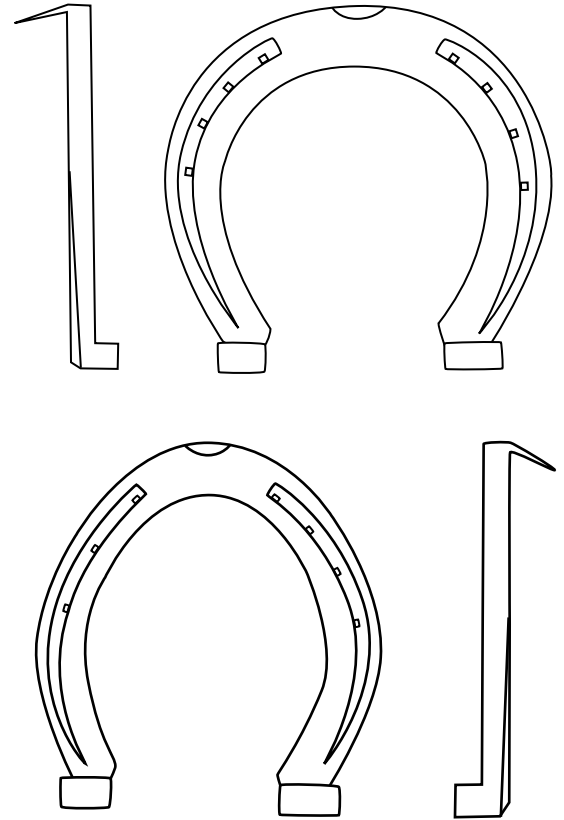

JOURNEYMAN CLASS

Sponsored by Farrier Academics

(John Blombach, CJF & Debora Ash, CF)

Four hammer-finished shoes will be made. The front pair will be forged from 12" x 3/8" x 3/4" bar stock, fullered, and punched for six nails (Delta 5 CH Slim) and will have hammer-drawn toe clips (any style hammer). No bob-punched clips are allowed.

The hind pair will be forged from 11 1/2" x 3/8" x 3/4" bar stock, fullered and punched for six nails (Delta 5 CH Slim) and will have hammer-drawn quarter clips (any style hammer). No bob-punched clips are allowed.

TIME LIMIT: 45 minutes

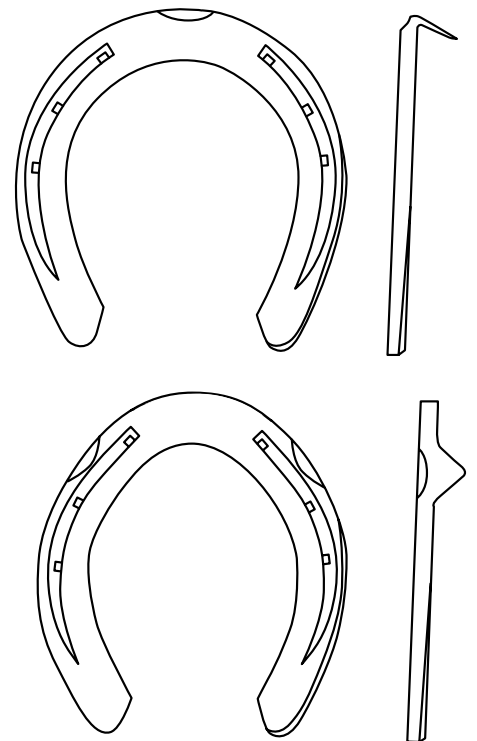

VERN HORNQUIST CLASS

Sponsored by Myron McLane, CJF & Walt Taylor, CF

Competitors will forge one shoe, for a near (left) hind foot. Billy Lewis, CJF, last year's winner, will be the judge and will provide a specimen.

TIME LIMIT: 60 minutes

HIND LATERAL SUPPORT SHOE

- $\frac{3}{8}$ " x 1" x 11"
- $\frac{3}{4}$ Fullered
- Quarter Clips
- Safed Toe
- 6 MX60 Nails

